

**12000 GALLON
73" LL
80" INLET**

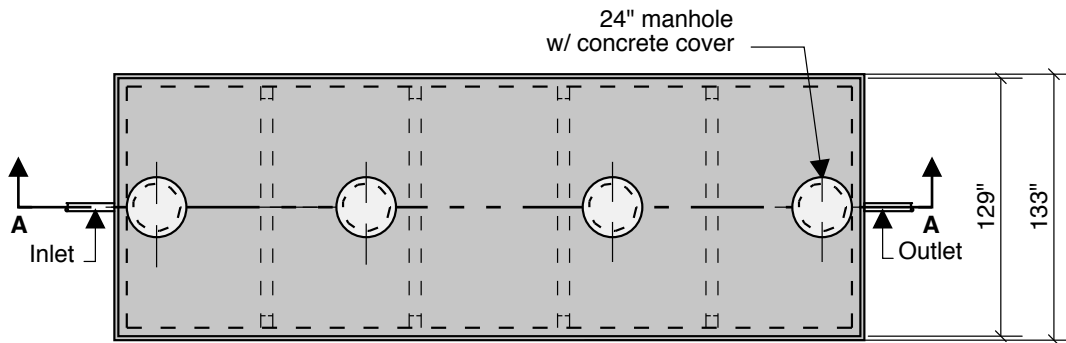

Top View

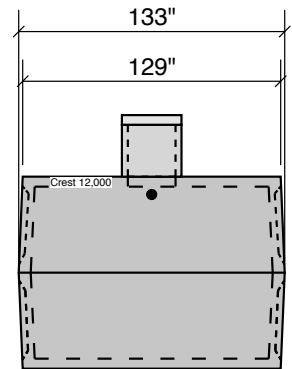

End View

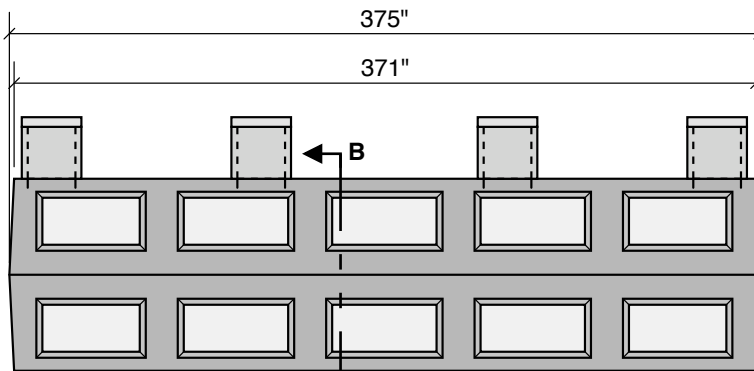

Side View

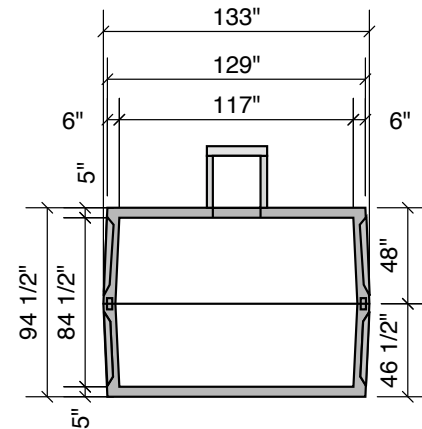

SECTION B-B

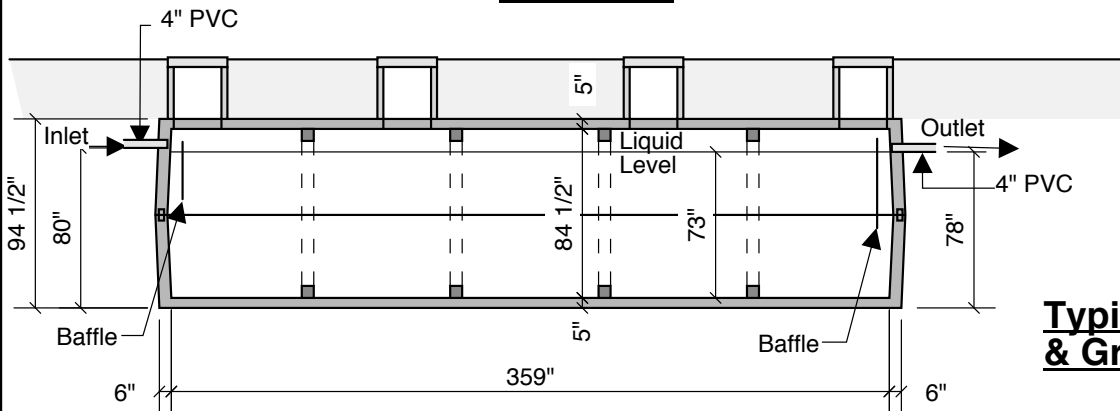

Section A-A

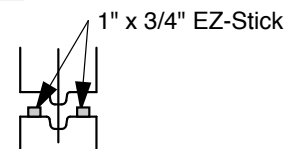

Typical Tongue & Groove Joint

Notes:
Concrete - 5000 PSI
Joint Sealant - High Grade EZ-Stick
Labels - Warning signs located on all manholes
Installation - See separate installation guide
Baffles Installed
Rubber Gaskets - Press Seal

Septic - Pump - Holding - Recirculation Or Grease Tank

Crest Precast, Inc.
La Crescent, MN & Barneveld, WI
800-658-9045

Scale		Drawn By:	KGT
Date		Revision	
Project:	SEPTIC TANK 12,000 GALLON		
Contractor:		Drawing Number	MODEL 12000