

**600 Septic 400 Septic 600 Pump
40" LL
45" INLET**

COMBINATION SEPTIC - PUMP

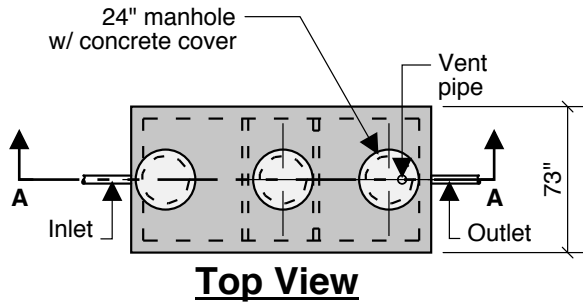

Top View

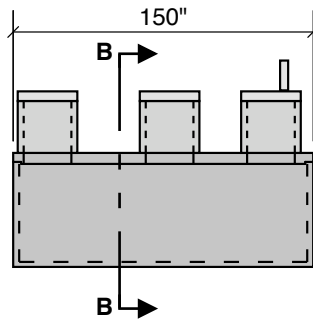

Side View

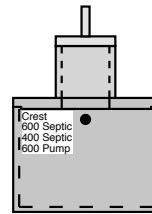

End View

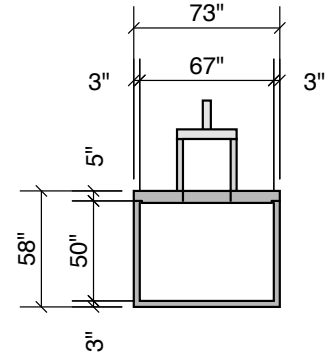

Section B-B

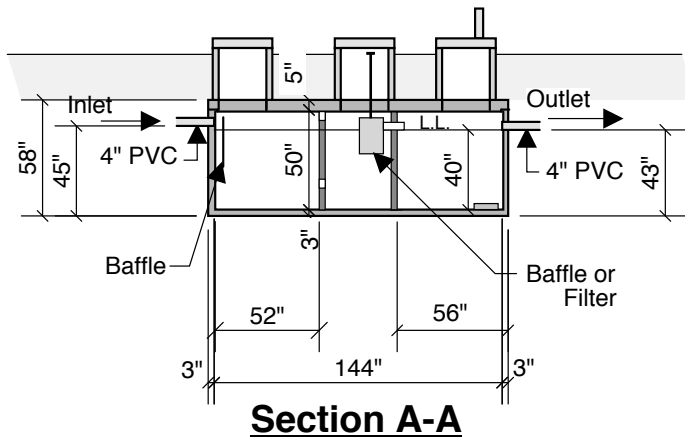

Section A-A

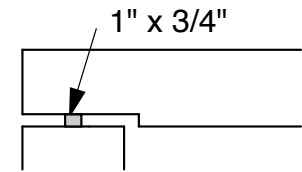

Typical Cover Detail

CREST MODEL 646

**Dual Septic Tank - 1000 Gallons
and Pump Chamber 600 Gallons**

**Septic Tank Size 1,000 gal
Pump Chamber Size 600 gal
15.4 G.P.I. in Pump Chamber**

- Notes:**
 Concrete - 5000 PSI
 Joint Sealant - High Grade EZ Stick
 Labels - Warning signs located on all manholes
 Installation - See separate installation guide
 Baffles Installed
 Rubber Gaskets - Press Seal
 Sealed Interior Wall

Crest Precast, Inc.		Drawn By: KGT
La Crescent, MN & Barneveld, WI		Revision
800-658-9045		
Scale		
Date		
Project:	SEPTIC-SEPTIC-PUMP TANK	
Contractor:	Drawing Number	MODEL 646