

**700 Septic 550 Pump
36" LL
41" INLET**

COMBINATION SEPTIC - PUMP

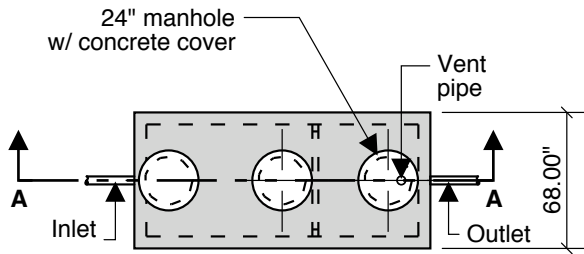

Top View

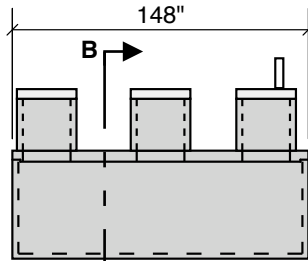

Side View

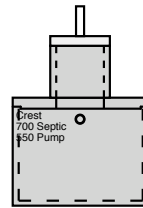

End View

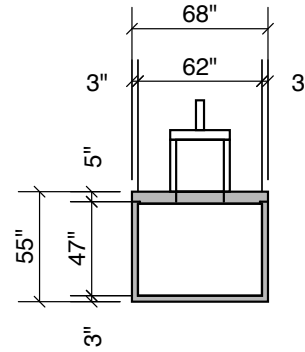

Section B-B

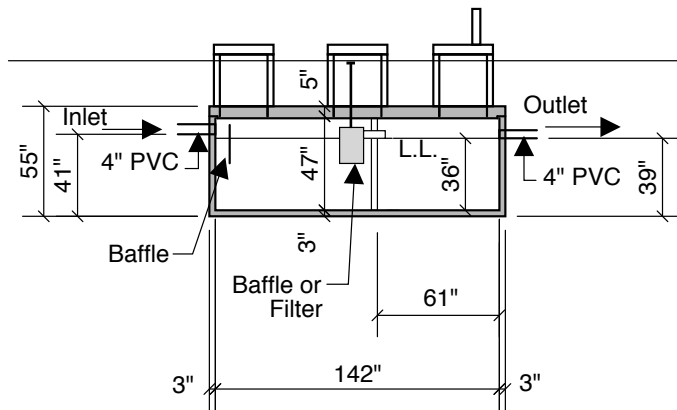

Section A-A

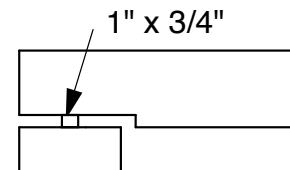

Typical Cover Detail

- Notes:
 Concrete - 5000 PSI
 Joint Sealant - High Grade EZ Stick
 Labels - Warning signs located on all manholes
 Installation - See separate installation guide
 Baffles Installed
 Rubber Gaskets - Press Seal
 Sealed Interior Wall

**Septic Tank Size 700 gal
 Pump Chamber Size 550 gal
 16.37 G.P.I. In Pump Chamber**

Crest Precast, Inc.
La Crescent, MN & Barneveld, WI
 800-658-9045

Scale		Drawn By:	KGT
Date		Revision	
Project:		SEPTIC-PUMP TANK	
Contractor:		Drawing Number	MODEL700-550-41